



Light Snow - 25 Degrees
 Schools in Session

Groups Printed- Cars - Buses - Trucks - Bicycles on Crosswalk - Pedestrians

Start Time	Courtland Boulevard From North							Shaker Boulevard From East							Montgomery Road From Southeast							Courtland boulevard From South							Manchester Road From Southwest							Shaker Boulevard From West							Int. Total
	Left	Bear Left	Thru	Bear Right	Right	Peds	App. Total	Hard Left	Left	Bear Left	Thru	Right	Peds	App. Total	Hard Left	Left	Bear Left	Thru	Right	Peds	App. Total	Hard Left	Left	Thru	Right	Hard Right	Peds	App. Total	Hard Left	Bear Left	Bear Right	Right	Hard Right	Peds	App. Total	Left	Thru	Bear Right	Right	Hard Right	Peds	App. Total	
07:00 AM	2	2	7	1	4	1	17	0	0	1	145	0	1	147	0	0	2	3	0	0	5	0	2	13	1	0	0	16	1	0	1	0	0	0	2	6	71	2	2	0	0	81	268
07:15 AM	5	3	16	0	7	0	31	0	1	1	153	3	0	158	0	0	3	1	0	2	6	0	8	21	1	0	3	33	0	0	4	0	0	2	6	7	104	3	2	0	1	117	351
07:30 AM	3	1	9	0	9	1	23	0	3	2	198	2	0	205	0	0	7	1	0	0	8	0	8	26	2	0	7	43	1	2	4	0	0	5	12	13	140	0	1	0	0	154	445
07:45 AM	11	8	13	0	17	0	49	0	2	1	181	0	0	184	0	0	9	6	0	0	15	0	8	34	2	0	2	46	1	3	2	0	0	0	6	8	137	2	3	1	0	151	451
Total	21	14	45	1	37	2	120	0	6	5	677	5	1	694	0	0	21	11	0	2	34	0	26	94	6	0	12	138	3	5	11	0	0	7	26	34	452	7	8	1	1	503	1515
08:00 AM	9	2	13	4	13	2	43	1	3	3	212	2	2	223	1	0	3	3	1	0	8	0	10	25	0	0	0	35	0	6	1	0	0	0	7	6	112	2	1	0	0	121	437
08:15 AM	9	2	12	3	2	1	29	1	0	3	180	3	1	188	0	0	7	3	0	0	10	0	6	14	1	0	1	22	0	2	1	0	0	0	3	5	129	2	3	1	2	142	394
08:30 AM	9	3	10	0	3	0	25	0	2	0	158	1	0	161	1	0	3	0	3	0	7	0	6	6	1	0	0	13	0	4	1	0	0	0	5	2	108	1	1	2	0	114	325
08:45 AM	7	3	7	1	3	0	21	0	3	0	121	2	0	126	0	0	3	3	3	0	9	0	4	7	0	0	0	11	0	2	0	0	0	0	2	5	101	2	2	0	1	111	280
Total	34	10	42	8	21	3	118	2	8	6	671	8	3	698	2	0	16	9	7	0	34	0	26	52	2	0	1	81	0	14	3	0	0	0	17	18	450	7	7	3	3	488	1436
09:00 AM	6	2	4	1	2	0	15	1	0	0	95	1	0	97	1	0	0	1	0	0	2	0	1	7	2	0	0	10	0	0	0	0	0	0	0	1	85	2	3	0	0	91	215
09:15 AM	2	0	5	0	3	0	10	0	0	0	91	1	0	92	0	0	1	1	0	0	2	0	1	4	0	0	0	5	0	1	0	0	0	1	2	2	73	3	2	0	1	81	192
09:30 AM	6	1	2	1	8	0	18	0	1	2	96	0	0	99	0	0	1	2	0	0	3	0	4	6	1	0	0	11	0	1	0	0	0	0	1	3	95	2	2	0	0	102	234
09:45 AM	1	2	5	1	6	0	15	0	0	1	68	0	0	69	0	0	1	0	1	0	2	0	1	8	1	0	0	10	0	1	0	0	0	0	1	1	84	1	0	0	1	87	184
Total	15	5	16	3	19	0	58	1	1	3	350	2	0	357	1	0	3	4	1	0	9	0	7	25	4	0	0	36	0	3	0	0	0	1	4	7	337	8	7	0	2	361	825
03:00 PM	6	2	8	0	8	1	25	0	2	8	73	2	1	86	0	0	1	1	0	0	2	0	5	18	2	0	1	26	0	0	2	0	0	0	2	6	133	1	1	0	0	141	282
03:15 PM	20	4	20	4	10	1	59	0	3	2	91	4	2	102	0	0	3	1	1	0	5	0	7	12	2	0	2	23	0	4	0	1	0	0	5	8	142	2	4	0	7	163	357
03:30 PM	20	3	20	3	8	2	56	0	3	0	104	1	0	108	0	0	2	0	1	0	3	0	2	16	2	0	0	20	0	0	4	0	0	0	4	10	128	2	1	0	0	141	332



File Name : Courtland_Avenue_at_Shaker_Boulevard_724432_11-14-2019
 Site Code : Site 1 - Thursday
 Start Date : 11/14/2019
 Page No : 2

Groups Printed- Cars - Buses - Trucks - Bicycles on Crosswalk - Pedestrians

Start Time	Courtland Boulevard From North							Shaker Boulevard From East							Montgomery Road From Southeast							Courtland boulevard From South							Manchester Road From Southwest							Shaker Boulevard From West							Int. Total													
	Left	Bear Left	Thru	Bear Right	Right	Peds	App. Total	Hard Left	Left	Bear Left	Thru	Right	Peds	App. Total	Hard Left	Left	Bear Left	Bear Right	Hard Right	Peds	App. Total	Hard Left	Left	Thru	Right	Hard Right	Peds	App. Total	Hard Left	Bear Left	Bear Right	Right	Hard Right	Peds	App. Total	Left	Thru	Bear Right	Right	Hard Right	Peds	App. Total														
03:45 PM	11	3	13	1	6	0	34	0	5	4	97	2	0	108	1	0	2	1	0	0	4	0	3	8	2	0	0	13	0	0	0	0	0	0	0	8	169	3	2	0	1	183	342													
Total	57	12	61	8	32	4	174	0	13	14	365	9	3	404	1	0	8	3	2	0	14	0	17	54	8	0	3	82	0	4	6	1	0	0	11	32	572	8	8	0	8	628	1313													
04:00 PM	4	0	6	0	12	0	22	0	2	1	102	0	0	105	0	0	0	4	0	0	4	0	0	20	4	0	3	27	0	0	0	0	1	1	2	5	179	4	3	0	1	192	352													
04:15 PM	7	7	7	4	10	0	35	0	6	2	105	2	0	115	0	0	0	2	0	0	2	0	0	15	3	0	0	18	0	3	0	0	0	0	3	3	166	2	2	0	0	173	346													
04:30 PM	12	5	13	1	6	0	37	0	1	2	101	4	0	108	0	0	1	2	2	0	5	0	2	17	1	0	1	21	0	2	0	0	0	0	2	7	168	2	1	1	1	180	353													
04:45 PM	13	2	11	2	16	0	44	0	0	0	120	2	0	122	0	0	4	3	0	0	7	0	3	20	4	0	0	27	0	1	2	0	0	0	3	4	160	5	4	0	0	173	376													
Total	36	14	37	7	44	0	138	0	9	5	428	8	0	450	0	0	5	11	2	0	18	0	5	72	12	0	4	93	0	6	2	0	1	1	10	19	673	13	10	1	2	718	1427													
05:00 PM	8	1	15	1	11	1	37	0	0	2	151	2	0	155	0	0	1	2	2	0	5	0	7	15	1	1	0	24	1	1	2	0	0	0	4	4	190	5	2	1	0	202	427													
05:15 PM	12	8	9	3	6	1	39	0	5	3	159	10	0	177	0	0	2	1	0	0	3	0	5	22	0	0	0	27	0	1	1	0	0	0	2	6	191	8	2	2	0	209	457													
05:30 PM	8	5	16	4	11	0	44	0	4	2	139	2	0	147	0	0	1	3	0	0	4	0	7	12	4	1	0	24	1	1	1	0	0	0	3	9	194	8	4	0	0	215	437													
05:45 PM	8	4	12	2	5	0	31	0	3	1	106	9	0	119	1	0	2	4	0	1	8	0	8	22	2	1	0	33	1	2	2	0	0	0	5	10	156	9	1	0	0	176	372													
Total	36	18	52	10	33	2	151	0	12	8	555	23	0	598	1	0	6	10	2	1	20	0	27	71	7	3	0	108	3	5	6	0	0	0	14	29	731	30	9	3	0	802	1693													
Grand Total	199	73	253	37	186	11	759	3	49	41	3046	55	7	3201	5	0	59	48	14	3	129	0	108	368	39	3	20	538	6	37	28	1	1	9	82	139	3215	73	49	8	16	3500	8209													
Apprch %	26.2	9.6	33.3	4.9	24.5	1.4		0.1	1.5	1.3	95.2	1.7	0.2		3.9	0	45.7	37.2	10.9	2.3		0	20.1	68.4	7.2	0.6	3.7		7.3	45.1	34.1	1.2	1.2	11		4	91.9	2.1	1.4	0.2	0.5															
Total %	2.4	0.9	3.1	0.5	2.3	0.1	9.2	0	0.6	0.5	37.1	0.7	0.1	39	0.1	0	0.7	0.6	0.2	0	1.6	0	1.3	4.5	0.5	0	0.2	6.6	0.1	0.5	0.3	0	0	0.1	1	1.7	39.2	0.9	0.6	0.1	0.2	42.6														
Cars	192	73	250	36	181	0	732	3	49	41	2995	53	0	3141	4	0	57	47	12	0	120	0	100	360	39	3	0	502	6	37	28	1	1	0	73	133	3181	69	47	6	0	3436	8004													
% Cars	96.5	100	98.8	97.3	97.3	0	96.4	100	100	100	98.3	96.4	0	98.1	80	0	96.6	97.9	85.7	0	93	0	92.6	97.8	100	100	0	93.3	100	100	100	100	100	0	89	95.7	98.9	94.5	95.9	75	0	98.2	97.5													
Buses	7	0	2	1	3	0	13	0	0	0	30	1	0	31	1	0	2	0	0	0	3	0	2	7	0	0	0	9	0	0	0	0	0	0	0	6	22	2	2	0	0	32	88													
% Buses	3.5	0	0.8	2.7	1.6	0	1.7	0	0	0	1	1.8	0	1	20	0	3.4	0	0	0	2.3	0	1.9	1.9	0	0	0	1.7	0	0	0	0	0	0	0	4.3	0.7	2.7	4.1	0	0	0.9	1.1													
Trucks	0	0	1	0	2	0	3	0	0	0	21	1	0	22	0	0	0	1	2	0	3	0	6	1	0	0	0	7	0	0	0	0	0	0	0	0	12	2	0	2	0	16	51													
% Trucks	0	0	0.4	0	1.1	0	0.4	0	0	0	0.7	1.8	0	0.7	0	0	0	2.1	14.3	0	2.3	0	5.6	0.3	0	0	0	1.3	0	0	0	0	0	0	0	0	0.4	2.7	0	25	0	0.5	0.6													
Bicycles on Crosswalk	0	0	0	0	0	0	0	0	0	0	0	0	0	0	0	0	0	0	0	0	0	0	0	0	0	0	0	0	0	0	0	0	0	0	0	0	0	0	0	0	0	0	0													
% Bicycles on Crosswalk	0	0	0	0	0	0	0	0	0	0	0	0	0	0	0	0	0	0	0	0	0	0	0	0	0	0	0	0	0	0	0	0	0	0	0	0	0	0	0	0	0	0	0													
Pedestrians	0	0	0	0	0	11	11	0	0	0	0	0	7	7	0	0	0	0	0	3	3	0	0	0	0	0	20	20	0	0	0	0	0	9	9	0	0	0	0	0	16	16	66													
% Pedestrians	0	0	0	0	0	100	1.4	0	0	0	0	0	100	0.2	0	0	0	0	0	100	2.3	0	0	0	0	0	100	3.7	0	0	0	0	0	100	11	0	0	0	0	0	100	0.5	0.8													



Cummins Consulting Services, PLLC
 2216 Young Drive, Suite 1, Lexington, KY 40505
 www.ccsdata.com Office: 859.785.1500
 "15 Years ... and still Counting"

File Name : Courtland_Avenue_at_Shaker_Boulevard_724432_11-14-2019
 Site Code : Site 1 - Thursday
 Start Date : 11/14/2019
 Page No : 4

Start Time	Courtland Boulevard From North							Shaker Boulevard From East							Montgomery Road From Southeast							Courtland boulevard From South							Manchester Road From Southwest							Shaker Boulevard From West							Int. Total
	Left	Bear Left	Thru	Bear Right	Right	Peds	App. Total	Hard Left	Left	Bear Left	Thru	Right	Peds	App. Total	Hard Left	Left	Bear Left	Bear Right	Hard Right	Peds	App. Total	Hard Left	Left	Thru	Right	Hard Right	Peds	App. Total	Hard Left	Bear Left	Bear Right	Right	Hard Right	Peds	App. Total	Left	Thru	Bear Right	Right	Hard Right	Peds	App. Total	
Peak Hour Analysis From 07:00 AM to 11:45 AM - Peak 1 of 1																																											
Peak Hour for Entire Intersection Begins at 07:30 AM																																											
07:30 AM	3	1	9	0	9	1	23	0	3	2	198	2	0	205	0	0	7	1	0	0	8	0	8	26	2	0	7	43	1	2	4	0	0	5	12	13	140	0	1	0	0	154	445
07:45 AM	11	8	13	0	17	0	49	0	2	1	181	0	0	184	0	0	9	6	0	0	15	0	8	34	2	0	2	46	1	3	2	0	0	0	6	8	137	2	3	1	0	151	451
08:00 AM	9	2	13	4	13	2	43	1	3	3	212	2	2	223	1	0	3	3	1	0	8	0	10	25	0	0	0	35	0	6	1	0	0	0	7	6	112	2	1	0	0	121	437
08:15 AM	9	2	12	3	2	1	29	1	0	3	180	3	1	188	0	0	7	3	0	0	10	0	6	14	1	0	1	22	0	2	1	0	0	0	3	5	129	2	3	1	2	142	394
Total Volume	32	13	47	7	41	4	144	2	8	9	771	7	3	800	1	0	26	13	1	0	41	0	32	99	5	0	10	146	2	13	8	0	0	5	28	32	518	6	8	2	2	568	1727
% App. Total	22.2	9	32.6	4.9	28.5	2.8		0.2	1	1.1	96.4	0.9	0.4		2.4	0	63.4	31.7	2.4	0		0	21.9	67.8	3.4	0	6.8	7.1	46.4	28.6	0	0	17.9		5.6	91.2	1.1	1.4	0.4	0.4			
PHF	.727	.406	.904	.438	.603	.500	.735	.500	.667	.750	.909	.583	.375	.897	.250	.000	.722	.542	.250	.000	.683	.000	.800	.728	.625	.000	.357	.793	.500	.542	.500	.000	.000	.250	.583	.615	.925	.750	.667	.500	.250	.922	.957



File Name : Courtland_Avenue_at_Shaker_Boulevard_724432_11-14-2019
 Site Code : Site 1 - Thursday
 Start Date : 11/14/2019
 Page No : 5

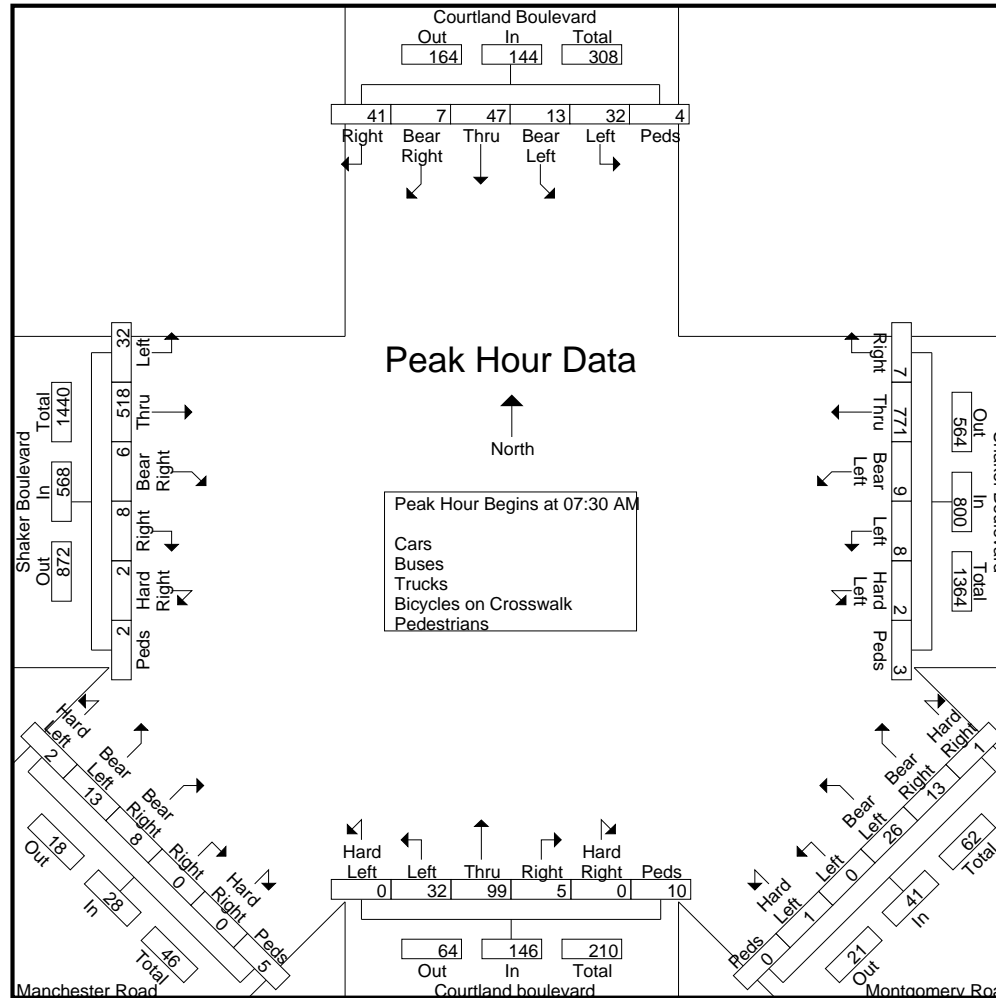



Cummins Consulting Services, PLLC
 2216 Young Drive, Suite 1, Lexington, KY 40505
 www.ccsdata.com Office: 859.785.1500
 "15 Years ... and still Counting"

File Name : Courtland_Avenue_at_Shaker_Boulevard_724432_11-14-2019
 Site Code : Site 1 - Thursday
 Start Date : 11/14/2019
 Page No : 6

Start Time	Courtland Boulevard From North							Shaker Boulevard From East							Montgomery Road From Southeast							Courtland boulevard From South							Manchester Road From Southwest							Shaker Boulevard From West							Int. Total
	Left	Bear Left	Thru	Bear Right	Right	Peds	App. Total	Hard Left	Left	Bear Left	Thru	Right	Peds	App. Total	Hard Left	Left	Bear Left	Bear Right	Hard Right	Peds	App. Total	Hard Left	Left	Thru	Right	Hard Right	Peds	App. Total	Hard Left	Bear Left	Bear Right	Right	Hard Right	Peds	App. Total	Left	Thru	Bear Right	Right	Hard Right	Peds	App. Total	
Peak Hour Analysis From 12:00 PM to 05:45 PM - Peak 1 of 1																																											
Peak Hour for Entire Intersection Begins at 04:45 PM																																											
04:45 PM	13	2	11	2	16	0	44	0	0	0	120	2	0	122	0	0	4	3	0	0	7	0	3	20	4	0	0	27	0	1	2	0	0	0	3	4	160	5	4	0	0	173	376
05:00 PM	8	1	15	1	11	1	37	0	0	2	151	2	0	155	0	0	1	2	2	0	5	0	7	15	1	1	0	24	1	1	2	0	0	0	4	4	190	5	2	1	0	202	427
05:15 PM	12	8	9	3	6	1	39	0	5	3	159	10	0	177	0	0	2	1	0	0	3	0	5	22	0	0	0	27	0	1	1	0	0	0	2	6	191	8	2	2	0	209	457
05:30 PM	8	5	16	4	11	0	44	0	4	2	139	2	0	147	0	0	1	3	0	0	4	0	7	12	4	1	0	24	1	1	1	0	0	0	3	9	194	8	4	0	0	215	437
Total Volume	41	16	51	10	44	2	164	0	9	7	569	16	0	601	0	0	8	9	2	0	19	0	22	69	9	2	0	102	2	4	6	0	0	0	12	23	735	26	12	3	0	799	1697
% App. Total	25	9.8	31.1	6.1	26.8	1.2		0	1.5	1.2	94.7	2.7	0		0	0	42.1	47.4	10.5	0		0	21.6	67.6	8.8	2	0		16.7	33.3	50	0	0	0		2.9	92	3.3	1.5	0.4	0		
PHF	.788	.500	.797	.625	.688	.500	.932	.000	.450	.583	.895	.400	.000	.849	.000	.000	.500	.750	.250	.000	.679	.000	.786	.784	.563	.500	.000	.944	.500	0	.750	.000	.000	.000	.750	.639	.947	.813	.750	.375	.000	.929	.928



File Name : Courtland_Avenue_at_Shaker_Boulevard_724432_11-14-2019
 Site Code : Site 1 - Thursday
 Start Date : 11/14/2019
 Page No : 7

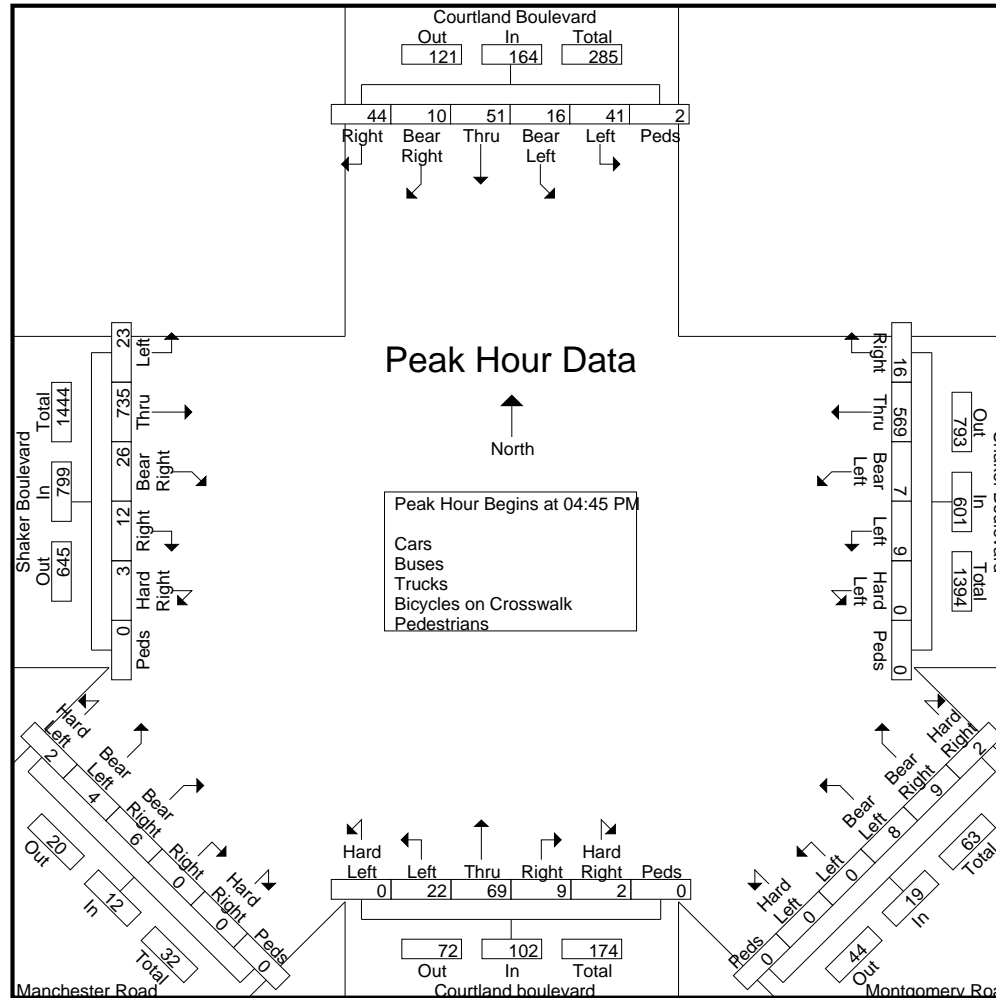



File Name : Courtland_Boulevard_at_N_Park_Boulevard_724437_11-14-2019

Light Snow - 25 Degrees Site Code : Site 3 - Thursday

Schools in Session Start Date : 11/14/2019

Page No : 1

Groups Printed- Cars - Buses - Trucks - Bicycles on Crosswalk - Pedestrians

Start Time	Courtland Boulevard From North					N Park Boulevard From East					Courtland Boulevard From South					N Park Boulevard From West					Int. Total
	Left	Thru	Right	Peds	App. Total	Left	Thru	Right	Peds	App. Total	Left	Thru	Right	Peds	App. Total	Left	Thru	Right	Peds	App. Total	
07:00 AM	3	12	0	0	15	3	2	1	0	6	1	6	7	0	14	1	1	2	1	5	40
07:15 AM	7	20	0	0	27	8	3	4	0	15	1	13	8	1	23	0	2	3	1	6	71
07:30 AM	18	23	1	0	42	11	6	8	0	25	2	13	34	1	50	0	11	3	0	14	131
07:45 AM	24	27	1	0	52	11	3	9	0	23	5	25	32	1	63	0	11	2	0	13	151
Total	52	82	2	0	136	33	14	22	0	69	9	57	81	3	150	1	25	10	2	38	393
08:00 AM	4	23	1	0	28	11	5	3	0	19	5	21	22	1	49	1	2	0	0	3	99
08:15 AM	1	19	1	2	23	6	2	2	1	11	1	23	16	0	40	0	1	4	0	5	79
08:30 AM	1	17	1	0	19	1	2	1	0	4	1	9	11	0	21	0	0	0	0	0	44
08:45 AM	1	14	2	1	18	3	1	1	0	5	3	16	6	0	25	0	1	0	0	1	49
Total	7	73	5	3	88	21	10	7	1	39	10	69	55	1	135	1	4	4	0	9	271
09:00 AM	1	9	1	0	11	2	2	0	0	4	1	9	6	0	16	0	1	1	0	2	33
09:15 AM	1	7	0	0	8	0	0	1	1	2	1	7	2	0	10	0	1	0	0	1	21
09:30 AM	0	5	0	0	5	2	1	0	1	4	4	8	3	0	15	0	0	1	0	1	25
09:45 AM	1	7	0	0	8	4	0	0	0	4	2	2	5	0	9	0	3	2	2	7	28
Total	3	28	1	0	32	8	3	1	2	14	8	26	16	0	50	0	5	4	2	11	107
03:00 PM	4	7	0	0	11	6	2	0	4	12	3	11	9	0	23	1	2	0	0	3	49
03:15 PM	5	17	2	1	25	7	4	2	1	14	2	37	26	1	66	3	6	3	3	15	120
03:30 PM	6	11	1	4	22	14	2	11	4	31	2	27	14	1	44	1	1	2	4	8	105
03:45 PM	4	9	0	0	13	9	4	3	0	16	4	18	5	0	27	0	1	1	2	4	60
Total	19	44	3	5	71	36	12	16	9	73	11	93	54	2	160	5	10	6	9	30	334
04:00 PM	2	10	0	0	12	3	2	3	0	8	2	18	10	0	30	0	2	0	0	2	52
04:15 PM	3	17	0	0	20	8	2	2	0	12	1	23	9	0	33	1	1	2	1	5	70
04:30 PM	6	12	2	0	20	8	0	1	0	9	4	26	14	1	45	2	2	0	0	4	78
04:45 PM	4	23	2	0	29	8	3	3	0	14	2	23	16	0	41	0	3	2	1	6	90
Total	15	62	4	0	81	27	7	9	0	43	9	90	49	1	149	3	8	4	2	17	290
05:00 PM	3	18	0	2	23	9	3	0	0	12	2	23	8	0	33	0	2	0	0	2	70
05:15 PM	2	20	0	0	22	5	1	0	1	7	4	26	14	0	44	1	1	1	0	3	76
05:30 PM	1	27	1	0	29	8	3	3	0	14	2	21	9	0	32	0	2	1	0	3	78
05:45 PM	3	18	1	0	22	3	0	1	0	4	2	35	16	0	53	0	2	0	0	2	81
Total	9	83	2	2	96	25	7	4	1	37	10	105	47	0	162	1	7	2	0	10	305
Grand Total	105	372	17	10	504	150	53	59	13	275	57	440	302	7	806	11	59	30	15	115	1700
Apprch %	20.8	73.8	3.4	2		54.5	19.3	21.5	4.7		7.1	54.6	37.5	0.9		9.6	51.3	26.1	13		
Total %	6.2	21.9	1	0.6	29.6	8.8	3.1	3.5	0.8	16.2	3.4	25.9	17.8	0.4	47.4	0.6	3.5	1.8	0.9	6.8	
Cars	104	365	15	0	484	149	52	56	0	257	57	423	287	0	767	9	56	29	0	94	1602
% Cars	99	98.1	88.2	0	96	99.3	98.1	94.9	0	93.5	100	96.1	95	0	95.2	81.8	94.9	96.7	0	81.7	94.2
Buses	1	7	1	0	9	0	0	3	0	3	0	16	12	0	28	1	3	0	0	4	44
% Buses	1	1.9	5.9	0	1.8	0	0	5.1	0	1.1	0	3.6	4	0	3.5	9.1	5.1	0	0	3.5	2.6
Trucks	0	0	1	0	1	1	1	0	0	2	0	1	3	0	4	1	0	1	0	2	9
% Trucks	0	0	5.9	0	0.2	0.7	1.9	0	0	0.7	0	0.2	1	0	0.5	9.1	0	3.3	0	1.7	0.5
Bicycles on Crosswalk	0	0	0	0	0	0	0	0	0	0	0	0	0	0	0	0	0	0	2	2	2
% Bicycles on Crosswalk	0	0	0	0	0	0	0	0	0	0	0	0	0	0	0	0	0	0	13.3	1.7	0.1
Pedestrians	0	0	0	10	10	0	0	0	13	13	0	0	0	7	7	0	0	0	13	13	43
% Pedestrians	0	0	0	100	2	0	0	0	100	4.7	0	0	0	100	0.9	0	0	0	86.7	11.3	2.5



File Name : Courtland_Boulevard_at_N_Park_Boulevard_724437_11-14-2019
 Site Code : Site 3 - Thursday
 Start Date : 11/14/2019
 Page No : 2

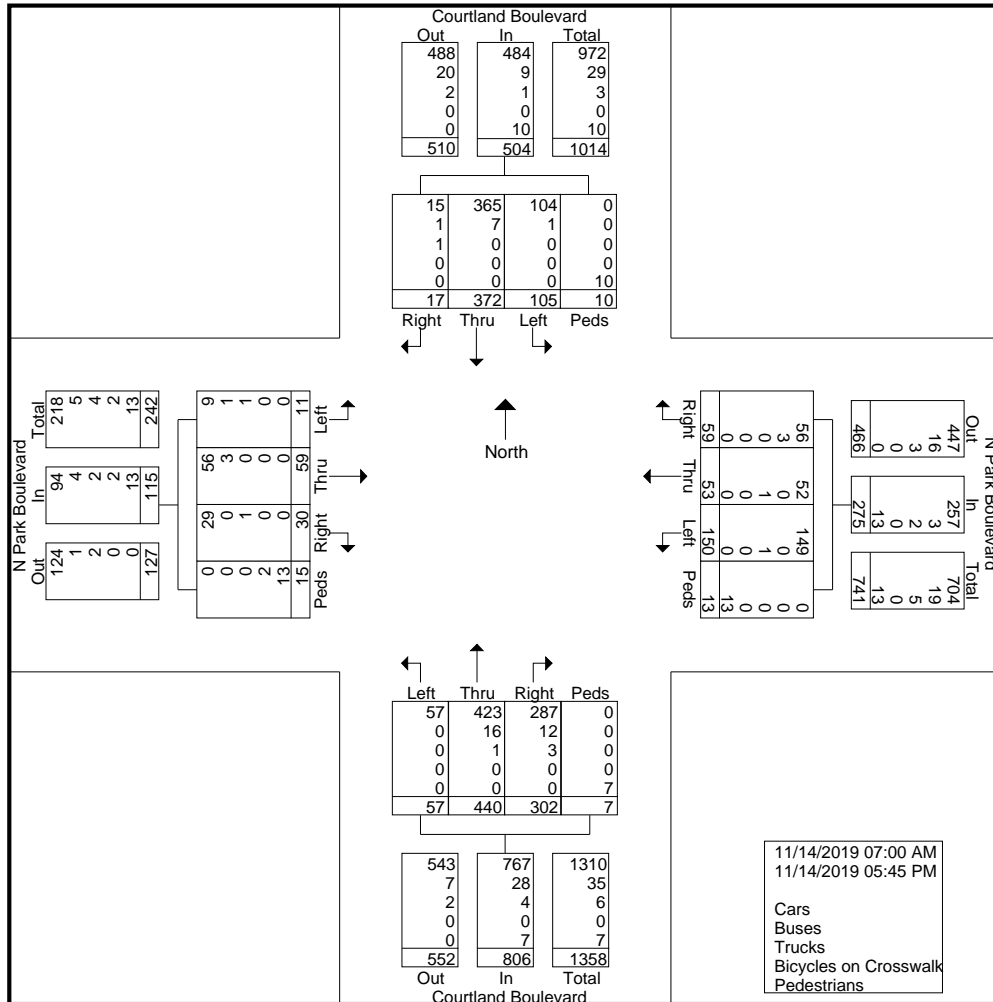



File Name : Courtland_Boulevard_at_N_Park_Boulevard_724437_11-14-2019
 Site Code : Site 3 - Thursday
 Start Date : 11/14/2019
 Page No : 3

Start Time	Courtland Boulevard From North					N Park Boulevard From East					Courtland Boulevard From South					N Park Boulevard From West					Int. Total
	Left	Thru	Right	Peds	App. Total	Left	Thru	Right	Peds	App. Total	Left	Thru	Right	Peds	App. Total	Left	Thru	Right	Peds	App. Total	
Peak Hour Analysis From 07:00 AM to 11:45 AM - Peak 1 of 1																					
Peak Hour for Entire Intersection Begins at 07:30 AM																					
07:30 AM	18	23	1	0	42	11	6	8	0	25	2	13	34	1	50	0	11	3	0	14	131
07:45 AM	24	27	1	0	52	11	3	9	0	23	5	25	32	1	63	0	11	2	0	13	151
08:00 AM	4	23	1	0	28	11	5	3	0	19	5	21	22	1	49	1	2	0	0	3	99
08:15 AM	1	19	1	2	23	6	2	2	1	11	1	23	16	0	40	0	1	4	0	5	79
Total Volume	47	92	4	2	145	39	16	22	1	78	13	82	104	3	202	1	25	9	0	35	460
% App. Total	32.4	63.4	2.8	1.4		50	20.5	28.2	1.3		6.4	40.6	51.5	1.5		2.9	71.4	25.7	0		
PHF	.490	.852	1.00	.250	.697	.886	.667	.611	.250	.780	.650	.820	.765	.750	.802	.250	.568	.563	.000	.625	.762

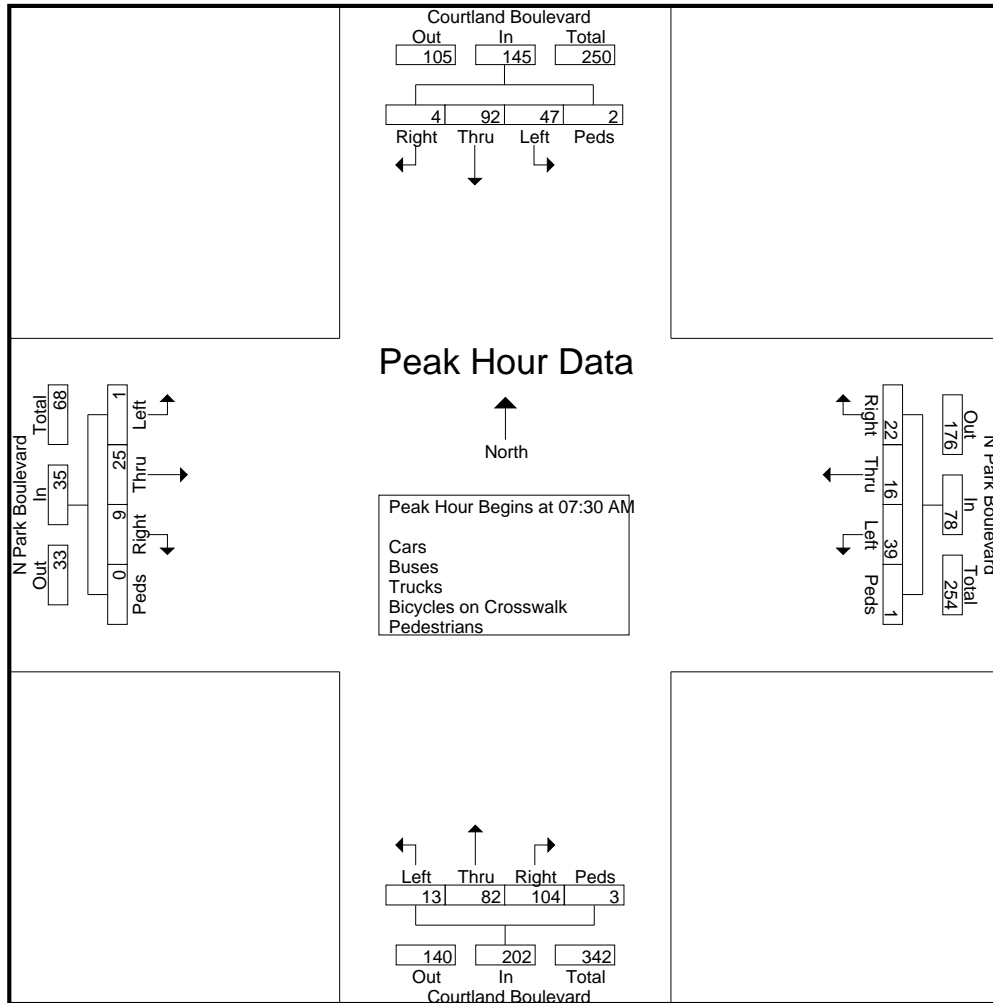



File Name : Courtland_Boulevard_at_N_Park_Boulevard_724437_11-14-2019
 Site Code : Site 3 - Thursday
 Start Date : 11/14/2019
 Page No : 4

Start Time	Courtland Boulevard From North					N Park Boulevard From East					Courtland Boulevard From South					N Park Boulevard From West					Int. Total
	Left	Thru	Right	Peds	App. Total	Left	Thru	Right	Peds	App. Total	Left	Thru	Right	Peds	App. Total	Left	Thru	Right	Peds	App. Total	
Peak Hour Analysis From 12:00 PM to 05:45 PM - Peak 1 of 1																					
Peak Hour for Entire Intersection Begins at 03:15 PM																					
03:15 PM	5	17	2	1	25	7	4	2	1	14	2	37	26	1	66	3	6	3	3	15	120
03:30 PM	6	11	1	4	22	14	2	11	4	31	2	27	14	1	44	1	1	2	4	8	105
03:45 PM	4	9	0	0	13	9	4	3	0	16	4	18	5	0	27	0	1	1	2	4	60
04:00 PM	2	10	0	0	12	3	2	3	0	8	2	18	10	0	30	0	2	0	0	2	52
Total Volume	17	47	3	5	72	33	12	19	5	69	10	100	55	2	167	4	10	6	9	29	337
% App. Total	23.6	65.3	4.2	6.9		47.8	17.4	27.5	7.2		6	59.9	32.9	1.2		13.8	34.5	20.7	31		
PHF	.708	.691	.375	.313	.720	.589	.750	.432	.313	.556	.625	.676	.529	.500	.633	.333	.417	.500	.563	.483	.702

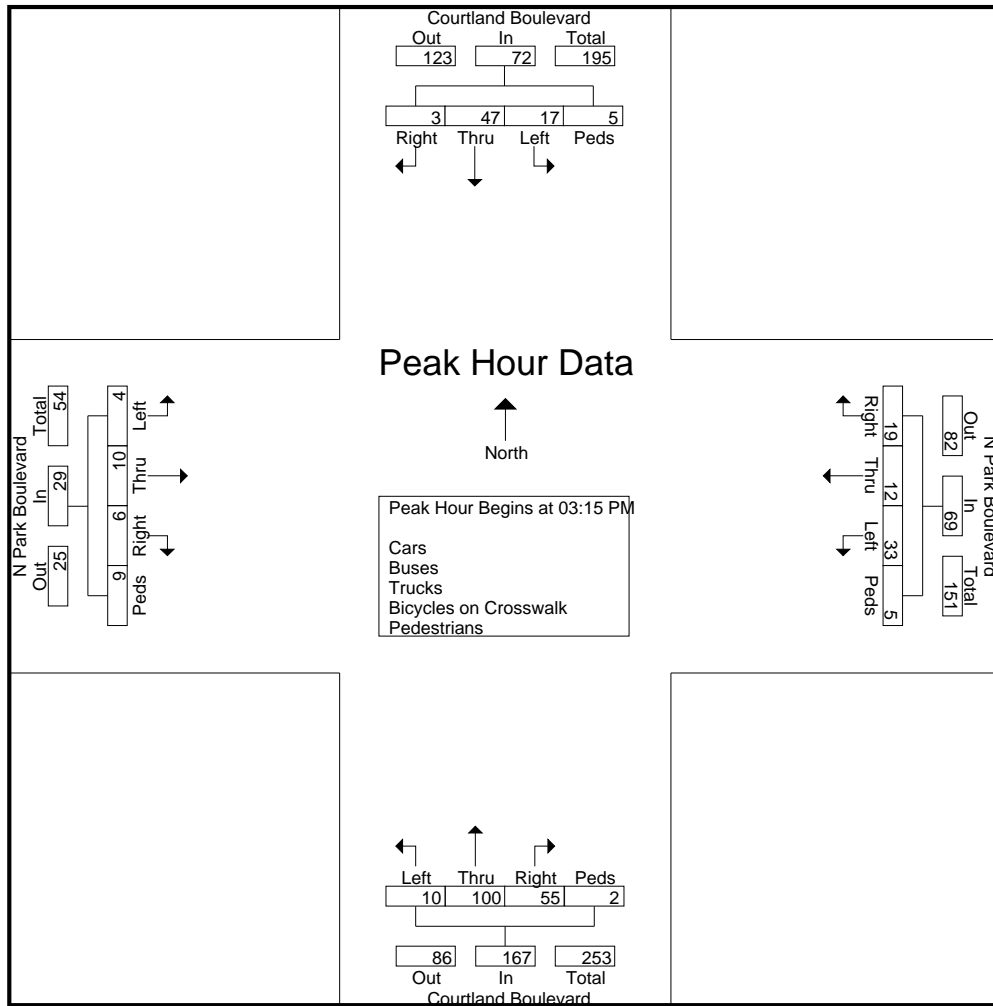



Light Snow - 25 Degrees
 Schools in Session

File Name : Courtland_Boulevard_at_Park_Boulevard_724435_11-14-2019
 Site Code : Site 2 - Thursday
 Start Date : 11/14/2019
 Page No : 1

Groups Printed- Cars - Buses - Trucks - Bicycles on Crosswalk - Pedestrians

Start Time	Courtland Boulevard From North					Park Boulevard From East					Courtland Boulevard From South					Park Boulevard From West					Int. Total
	Left	Thru	Right	Peds	App. Total	Left	Thru	Right	Peds	App. Total	Left	Thru	Right	Peds	App. Total	Left	Thru	Right	Peds	App. Total	
07:00 AM	2	11	0	0	13	1	46	3	1	51	3	17	0	0	20	5	3	3	0	11	95
07:15 AM	3	22	2	0	27	5	53	15	2	75	4	25	1	0	30	9	10	4	0	23	155
07:30 AM	2	20	4	1	27	4	41	32	1	78	2	38	7	0	47	11	11	2	0	24	176
07:45 AM	2	33	3	0	38	10	46	32	4	92	5	38	4	1	48	15	18	9	0	42	220
Total	9	86	9	1	105	20	186	82	8	296	14	118	12	1	145	40	42	18	0	100	646
08:00 AM	6	36	9	1	52	6	55	32	4	97	3	37	6	0	46	6	8	3	2	19	214
08:15 AM	3	24	3	0	30	1	43	12	2	58	6	20	2	0	28	3	8	4	0	15	131
08:30 AM	1	22	0	0	23	2	48	5	0	55	1	5	3	0	9	1	10	2	1	14	101
08:45 AM	0	11	3	1	15	3	44	4	0	51	5	13	0	0	18	2	8	7	1	18	102
Total	10	93	15	2	120	12	190	53	6	261	15	75	11	0	101	12	34	16	4	66	548
09:00 AM	0	11	1	0	12	2	41	3	0	46	2	9	1	1	13	3	9	2	0	14	85
09:15 AM	0	7	1	1	9	0	27	4	1	32	2	7	0	1	10	0	3	2	0	5	56
09:30 AM	0	8	0	1	9	6	27	7	0	40	3	8	0	0	11	0	2	3	0	5	65
09:45 AM	0	12	1	2	15	2	22	0	1	25	1	7	0	0	8	1	7	1	0	9	57
Total	0	38	3	4	45	10	117	14	2	143	8	31	1	2	42	4	21	8	0	33	263
03:00 PM	4	15	2	0	21	2	13	14	0	29	2	15	8	1	26	6	14	4	2	26	102
03:15 PM	7	45	4	0	56	9	33	24	3	69	1	27	5	0	33	6	11	5	2	24	182
03:30 PM	1	42	5	0	48	7	28	7	4	46	1	20	3	0	24	2	11	5	1	19	137
03:45 PM	1	16	5	2	24	5	23	8	2	38	3	17	4	0	24	9	9	11	2	31	117
Total	13	118	16	2	149	23	97	53	9	182	7	79	20	1	107	23	45	25	7	100	538
04:00 PM	1	15	1	1	18	6	26	5	3	40	3	21	4	2	30	3	8	3	1	15	103
04:15 PM	1	21	2	0	24	7	29	9	1	46	3	18	6	0	27	6	15	5	0	26	123
04:30 PM	0	27	2	0	29	3	25	5	0	33	2	23	4	0	29	7	16	9	0	32	123
04:45 PM	6	28	3	1	38	6	21	8	1	36	3	30	1	1	35	5	17	8	0	30	139
Total	8	91	8	2	109	22	101	27	5	155	11	92	15	3	121	21	56	25	1	103	488
05:00 PM	2	28	1	1	32	6	26	5	0	37	4	16	4	1	25	3	14	2	0	19	113
05:15 PM	4	23	1	0	28	4	36	10	1	51	6	30	4	0	40	2	19	11	0	32	151
05:30 PM	3	33	6	2	44	6	43	4	0	53	3	22	2	0	27	1	15	8	0	24	148
05:45 PM	1	21	0	0	22	2	39	7	0	48	1	35	8	0	44	5	15	6	0	26	140
Total	10	105	8	3	126	18	144	26	1	189	14	103	18	1	136	11	63	27	0	101	552
Grand Total	50	531	59	14	654	105	835	255	31	1226	69	498	77	8	652	111	261	119	12	503	3035
Apprch %	7.6	81.2	9	2.1		8.6	68.1	20.8	2.5		10.6	76.4	11.8	1.2		22.1	51.9	23.7	2.4		
Total %	1.6	17.5	1.9	0.5	21.5	3.5	27.5	8.4	1	40.4	2.3	16.4	2.5	0.3	21.5	3.7	8.6	3.9	0.4	16.6	
Cars	48	518	58	0	624	102	832	239	0	1173	68	483	77	0	628	107	257	119	0	483	2908
% Cars	96	97.6	98.3	0	95.4	97.1	99.6	93.7	0	95.7	98.6	97	100	0	96.3	96.4	98.5	100	0	96	95.8
Buses	2	12	1	0	15	1	1	14	0	16	1	13	0	0	14	3	3	0	0	6	51
% Buses	4	2.3	1.7	0	2.3	1	0.1	5.5	0	1.3	1.4	2.6	0	0	2.1	2.7	1.1	0	0	1.2	1.7
Trucks	0	1	0	0	1	2	2	2	0	6	0	2	0	0	2	1	1	0	0	2	11
% Trucks	0	0.2	0	0	0.2	1.9	0.2	0.8	0	0.5	0	0.4	0	0	0.3	0.9	0.4	0	0	0.4	0.4
Bicycles on Crosswalk	0	0	0	0	0	0	0	0	0	0	0	0	0	0	0	0	0	0	0	0	0
% Bicycles on Crosswalk	0	0	0	0	0	0	0	0	0	0	0	0	0	0	0	0	0	0	0	0	0
Pedestrians	0	0	0	14	14	0	0	0	31	31	0	0	0	8	8	0	0	0	12	12	65
% Pedestrians	0	0	0	100	2.1	0	0	0	100	2.5	0	0	0	100	1.2	0	0	0	100	2.4	2.1



File Name : Courtland_Boulevard_at_Park_Boulevard_724435_11-14-2019
 Site Code : Site 2 - Thursday
 Start Date : 11/14/2019
 Page No : 2

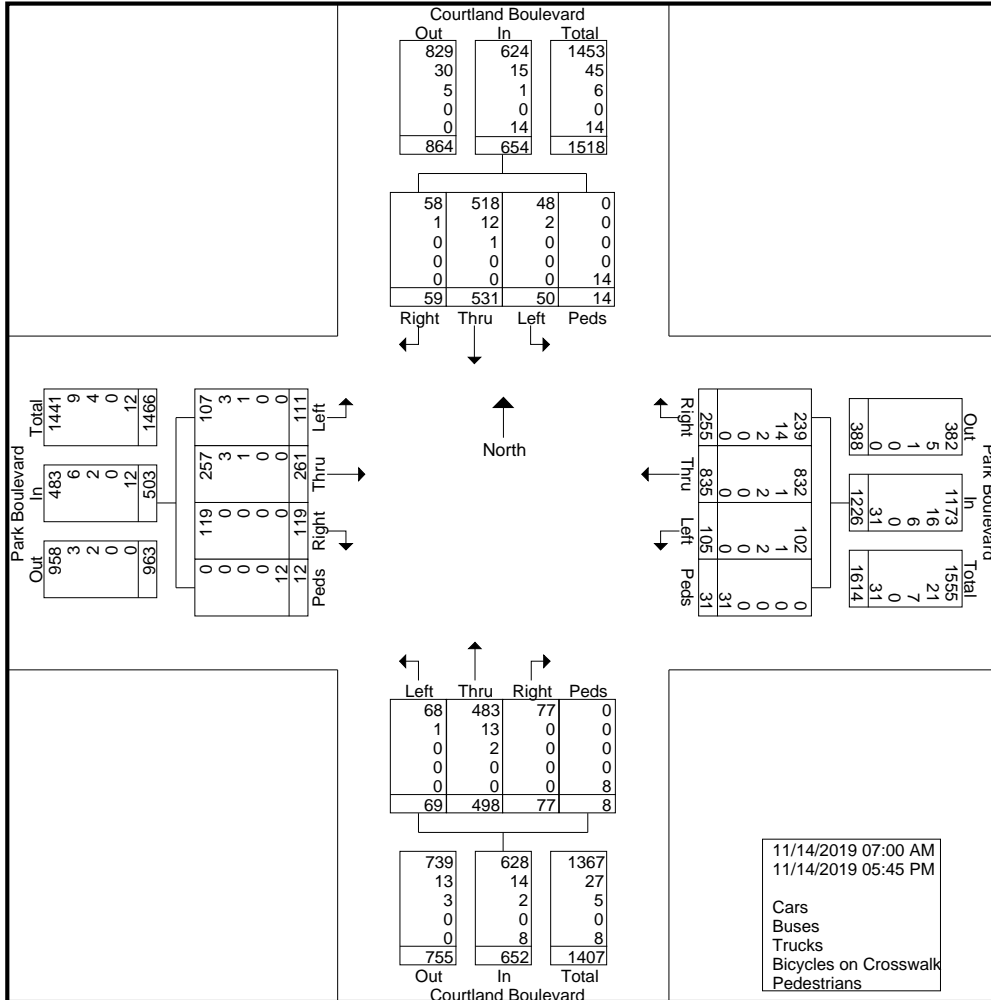



File Name : Courtland_Boulevard_at_Park_Boulevard_724435_11-14-2019
 Site Code : Site 2 - Thursday
 Start Date : 11/14/2019
 Page No : 3

Start Time	Courtland Boulevard From North					Park Boulevard From East					Courtland Boulevard From South					Park Boulevard From West					Int. Total
	Left	Thru	Right	Peds	App. Total	Left	Thru	Right	Peds	App. Total	Left	Thru	Right	Peds	App. Total	Left	Thru	Right	Peds	App. Total	
Peak Hour Analysis From 07:00 AM to 12:30 PM - Peak 1 of 1																					
Peak Hour for Entire Intersection Begins at 07:15 AM																					
07:15 AM	3	22	2	0	27	5	53	15	2	75	4	25	1	0	30	9	10	4	0	23	155
07:30 AM	2	20	4	1	27	4	41	32	1	78	2	38	7	0	47	11	11	2	0	24	176
07:45 AM	2	33	3	0	38	10	46	32	4	92	5	38	4	1	48	15	18	9	0	42	220
08:00 AM	6	36	9	1	52	6	55	32	4	97	3	37	6	0	46	6	8	3	2	19	214
Total Volume	13	111	18	2	144	25	195	111	11	342	14	138	18	1	171	41	47	18	2	108	765
% App. Total	9	77.1	12.5	1.4		7.3	57	32.5	3.2		8.2	80.7	10.5	0.6		38	43.5	16.7	1.9		
PHF	.542	.771	.500	.500	.692	.625	.886	.867	.688	.881	.700	.908	.643	.250	.891	.683	.653	.500	.250	.643	.869

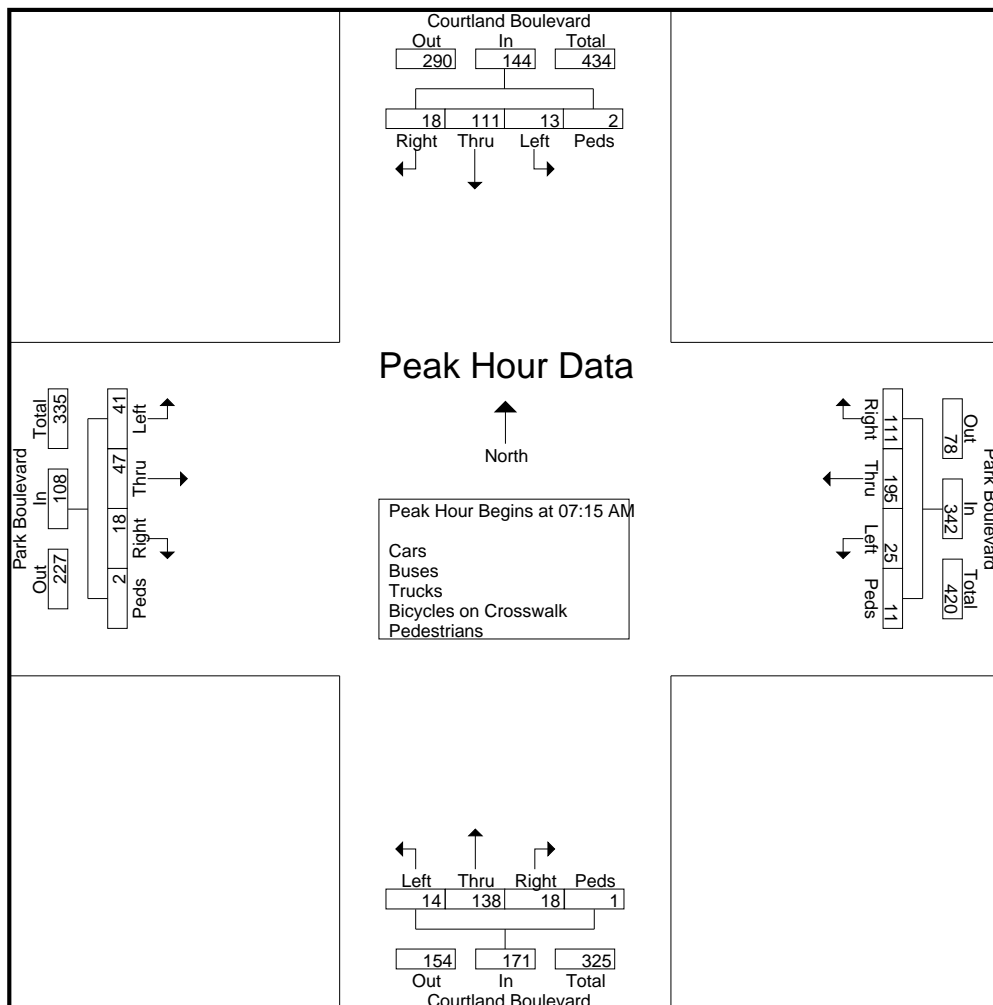



File Name : Courtland_Boulevard_at_Park_Boulevard_724435_11-14-2019
 Site Code : Site 2 - Thursday
 Start Date : 11/14/2019
 Page No : 4

Start Time	Courtland Boulevard From North					Park Boulevard From East					Courtland Boulevard From South					Park Boulevard From West					Int. Total
	Left	Thru	Right	Peds	App. Total	Left	Thru	Right	Peds	App. Total	Left	Thru	Right	Peds	App. Total	Left	Thru	Right	Peds	App. Total	
Peak Hour Analysis From 12:45 PM to 05:45 PM - Peak 1 of 1																					
Peak Hour for Entire Intersection Begins at 05:00 PM																					
05:00 PM	2	28	1	1	32	6	26	5	0	37	4	16	4	1	25	3	14	2	0	19	113
05:15 PM	4	23	1	0	28	4	36	10	1	51	6	30	4	0	40	2	19	11	0	32	151
05:30 PM	3	33	6	2	44	6	43	4	0	53	3	22	2	0	27	1	15	8	0	24	148
05:45 PM	1	21	0	0	22	2	39	7	0	48	1	35	8	0	44	5	15	6	0	26	140
Total Volume	10	105	8	3	126	18	144	26	1	189	14	103	18	1	136	11	63	27	0	101	552
% App. Total	7.9	83.3	6.3	2.4		9.5	76.2	13.8	0.5		10.3	75.7	13.2	0.7		10.9	62.4	26.7	0		
PHF	.625	.795	.333	.375	.716	.750	.837	.650	.250	.892	.583	.736	.563	.250	.773	.550	.829	.614	.000	.789	.914

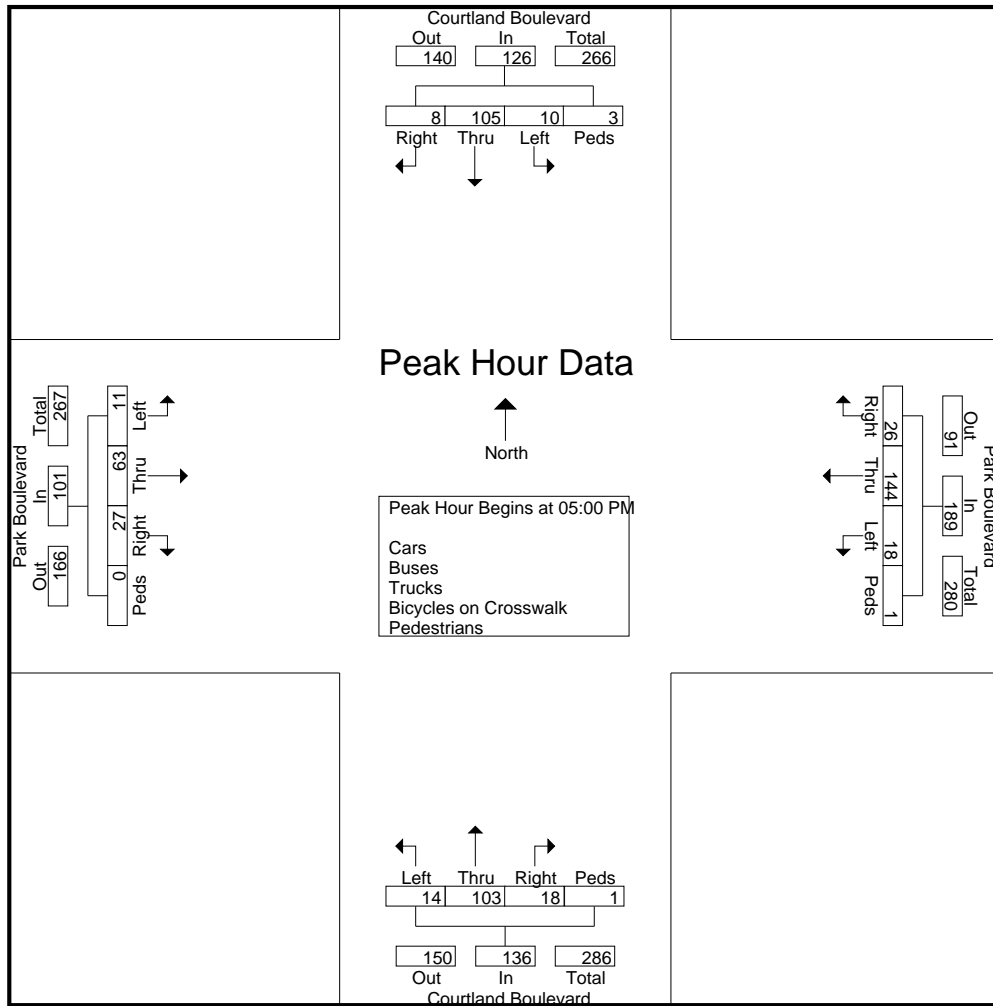



File Name : S_Park_Boulevard_at_Shebrooke_Road_724440_11-14-2019
 Site Code : Site 4 - Thursday
 Start Date : 11/14/2019
 Page No : 2

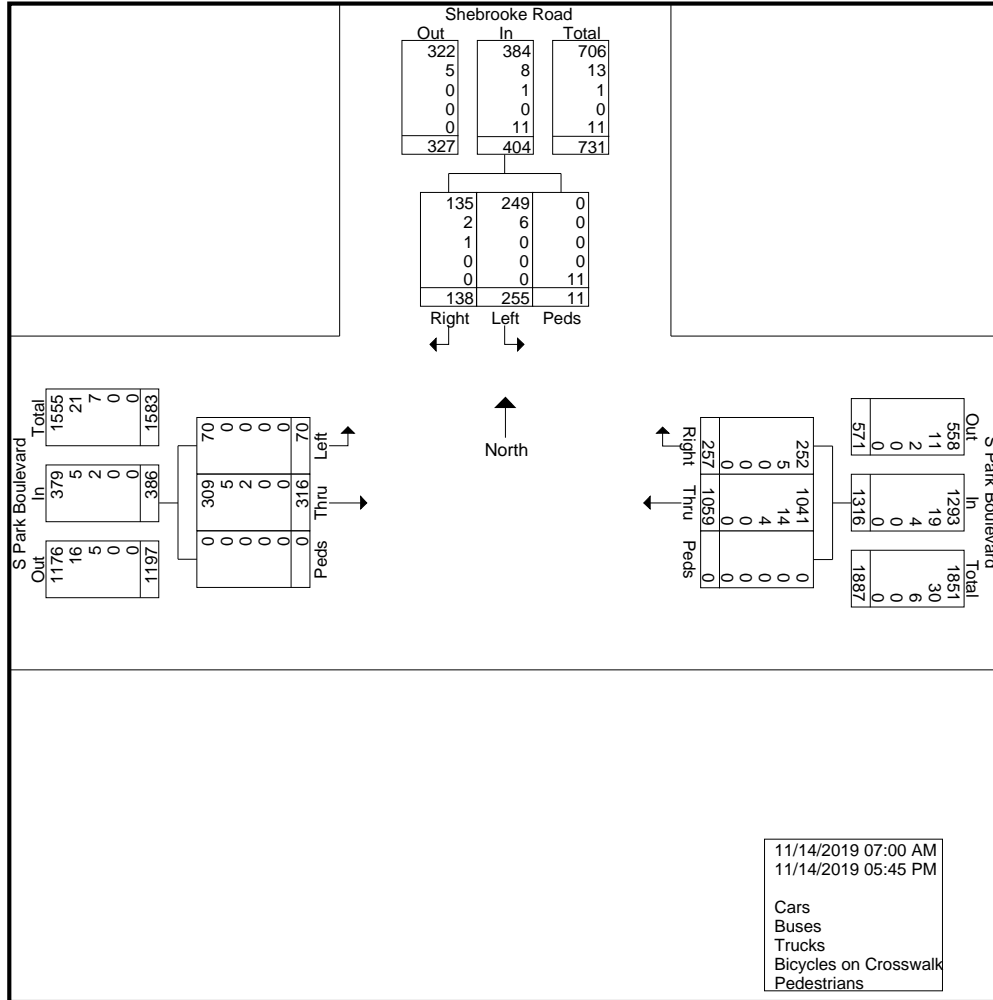



File Name : S_Park_Boulevard_at_Shebrooke_Road_724440_11-14-2019
 Site Code : Site 4 - Thursday
 Start Date : 11/14/2019
 Page No : 3

Start Time	Shebrooke Road From North				S Park Boulevard From East				S Park Boulevard From West				Int. Total
	Left	Right	Peds	App. Total	Thru	Right	Peds	App. Total	Left	Thru	Peds	App. Total	
Peak Hour Analysis From 07:00 AM to 11:45 AM - Peak 1 of 1													
Peak Hour for Entire Intersection Begins at 07:15 AM													
07:15 AM	3	5	0	8	73	27	0	100	1	13	0	14	122
07:30 AM	23	9	1	33	62	57	0	119	8	11	0	19	171
07:45 AM	33	23	0	56	72	47	0	119	9	15	0	24	199
08:00 AM	12	6	0	18	81	6	0	87	4	15	0	19	124
Total Volume	71	43	1	115	288	137	0	425	22	54	0	76	616
% App. Total	61.7	37.4	0.9		67.8	32.2	0		28.9	71.1	0		
PHF	.538	.467	.250	.513	.889	.601	.000	.893	.611	.900	.000	.792	.774

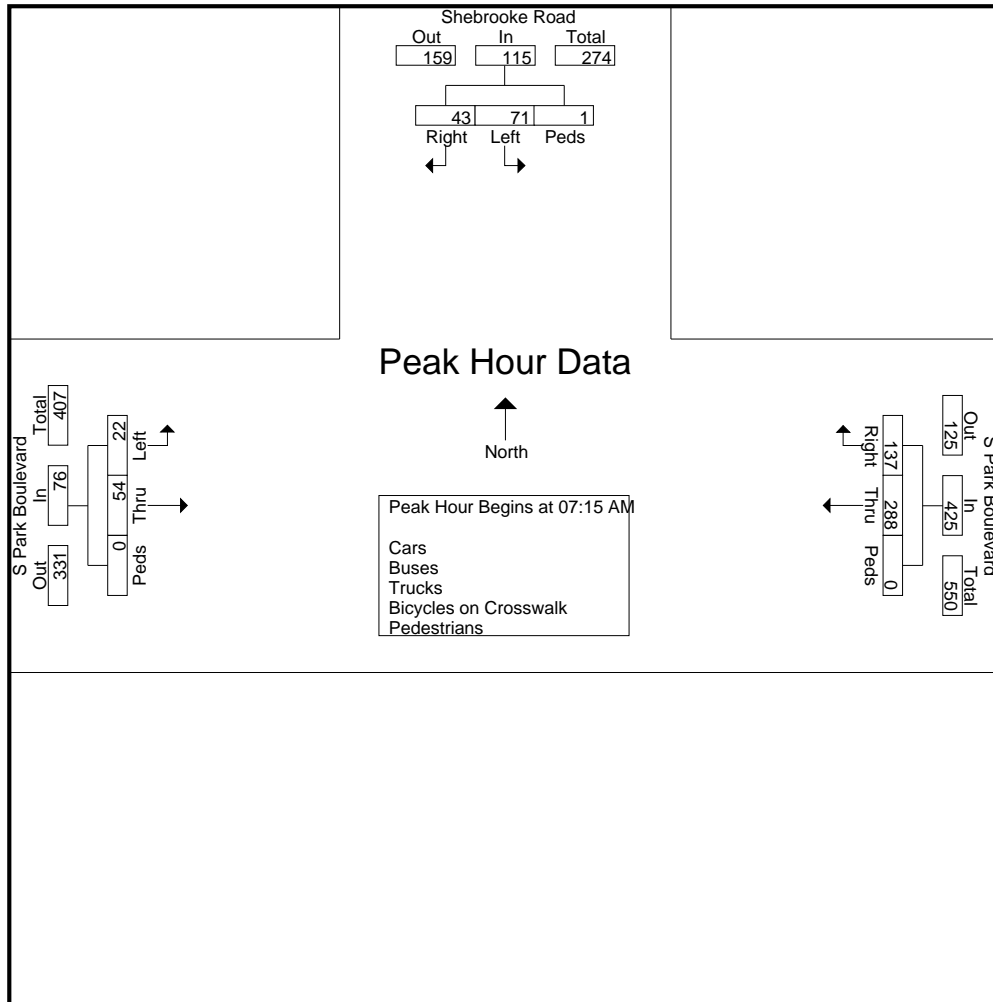



File Name : S_Park_Boulevard_at_Shebrooke_Road_724440_11-14-2019
 Site Code : Site 4 - Thursday
 Start Date : 11/14/2019
 Page No : 4

Start Time	Shebrooke Road From North				S Park Boulevard From East				S Park Boulevard From West				Int. Total
	Left	Right	Peds	App. Total	Thru	Right	Peds	App. Total	Left	Thru	Peds	App. Total	
Peak Hour Analysis From 12:00 PM to 05:45 PM - Peak 1 of 1													
Peak Hour for Entire Intersection Begins at 03:00 PM													
03:00 PM	5	5	1	11	22	8	0	30	8	16	0	24	65
03:15 PM	37	20	0	57	42	22	0	64	8	16	0	24	145
03:30 PM	25	13	2	40	28	16	0	44	3	11	0	14	98
03:45 PM	12	5	1	18	33	6	0	39	2	13	0	15	72
Total Volume	79	43	4	126	125	52	0	177	21	56	0	77	380
% App. Total	62.7	34.1	3.2		70.6	29.4	0		27.3	72.7	0		
PHF	.534	.538	.500	.553	.744	.591	.000	.691	.656	.875	.000	.802	.655

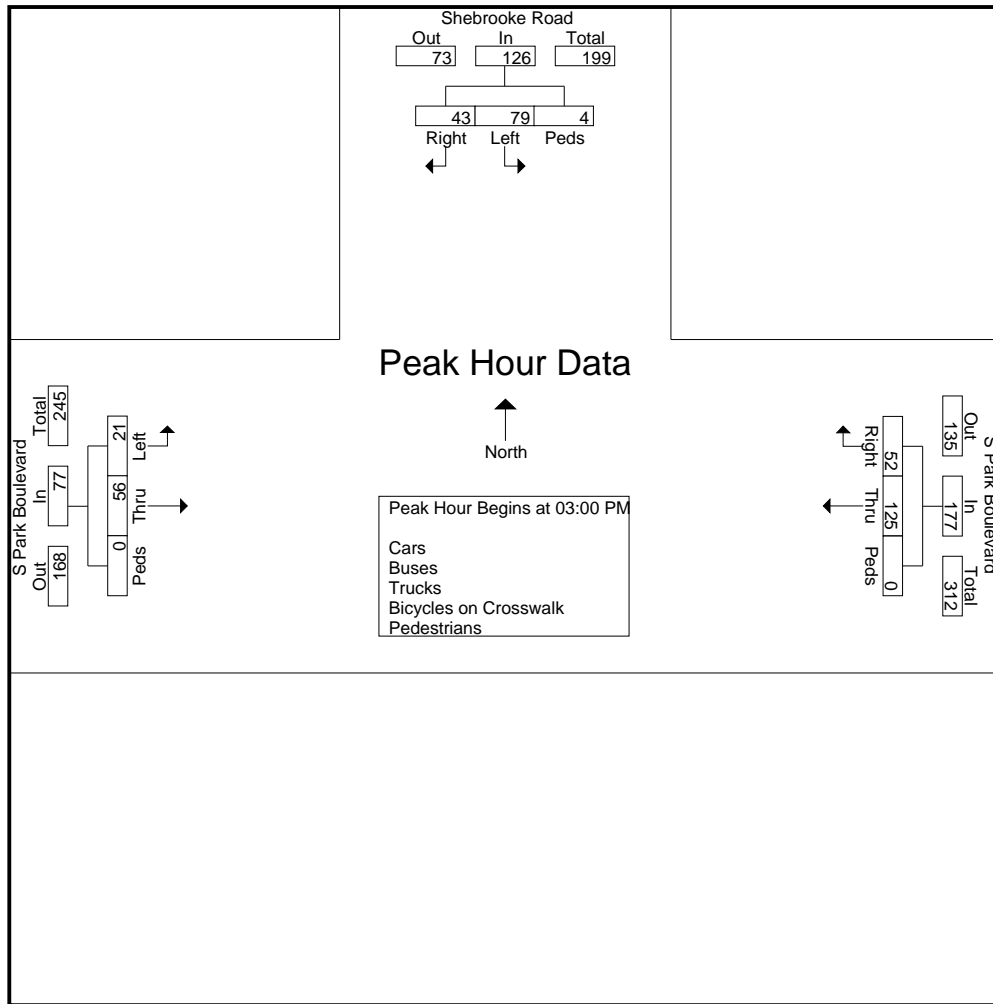



File Name : Warrensville_Center_Road_at_Shelburne_Road_724444_11-14-2019

Light Snow - 25 Degrees Site Code : Site 5 - Thursday

Schools in Session Start Date : 11/14/2019

Page No : 1

Groups Printed- Cars - Buses - Trucks - Bicycles on Crosswalk - Pedestrians

Start Time	Warrensville Center Road From North					Shelburne Road From East					Warrensville Center Road From South					Shelburne Road From West					Int. Total
	Left	Thru	Right	Peds	App. Total	Left	Thru	Right	Peds	App. Total	Left	Thru	Right	Peds	App. Total	Left	Thru	Right	Peds	App. Total	
07:00 AM	2	137	2	1	142	1	12	0	1	14	3	87	0	1	91	1	5	0	0	6	253
07:15 AM	6	162	0	0	168	3	20	0	0	23	10	114	1	0	125	0	15	11	0	26	342
07:30 AM	6	181	2	0	189	1	52	0	1	54	14	124	2	0	140	4	28	16	0	48	431
07:45 AM	3	176	2	0	181	3	36	1	0	40	13	158	2	0	173	6	46	18	0	70	464
Total	17	656	6	1	680	8	120	1	2	131	40	483	5	1	529	11	94	45	0	150	1490
08:00 AM	3	178	3	0	184	1	38	3	0	42	4	165	4	0	173	4	14	11	0	29	428
08:15 AM	3	194	3	0	200	0	19	0	0	19	8	127	0	0	135	2	4	9	0	15	369
08:30 AM	1	194	0	0	195	2	13	1	0	16	7	146	5	0	158	2	5	6	0	13	382
08:45 AM	3	187	2	0	192	1	14	0	0	15	8	147	3	0	158	1	4	2	1	8	373
Total	10	753	8	0	771	4	84	4	0	92	27	585	12	0	624	9	27	28	1	65	1552
09:00 AM	5	148	1	0	154	1	10	0	1	12	6	144	2	0	152	4	3	5	0	12	330
09:15 AM	5	141	1	0	147	2	8	0	0	10	4	142	5	0	151	2	6	3	0	11	319
09:30 AM	3	139	1	0	143	2	2	2	0	6	2	143	2	0	147	2	0	4	0	6	302
09:45 AM	1	139	1	0	141	1	3	1	0	5	2	128	0	0	130	3	2	4	0	9	285
Total	14	567	4	0	585	6	23	3	1	33	14	557	9	0	580	11	11	16	0	38	1236
03:00 PM	7	196	0	0	203	2	10	1	0	13	4	148	4	0	156	2	19	12	0	33	405
03:15 PM	6	186	4	0	196	1	19	2	0	22	6	181	4	0	191	6	36	10	0	52	461
03:30 PM	5	211	1	2	219	3	15	0	1	19	6	188	3	0	197	8	28	10	0	46	481
03:45 PM	6	208	2	0	216	2	8	0	0	10	7	188	2	1	198	7	15	6	1	29	453
Total	24	801	7	2	834	8	52	3	1	64	23	705	13	1	742	23	98	38	1	160	1800
04:00 PM	5	209	3	1	218	2	6	1	0	9	7	163	1	3	174	8	18	4	0	30	431
04:15 PM	3	223	3	0	229	2	9	1	0	12	7	202	6	0	215	9	23	10	0	42	498
04:30 PM	6	213	1	1	221	0	8	1	0	9	8	193	2	0	203	7	35	9	0	51	484
04:45 PM	9	183	2	0	194	2	14	1	1	18	11	199	1	1	212	6	29	10	0	45	469
Total	23	828	9	2	862	6	37	4	1	48	33	757	10	4	804	30	105	33	0	168	1882
05:00 PM	3	234	0	0	237	1	8	3	0	12	5	226	3	0	234	9	25	5	0	39	522
05:15 PM	2	258	2	0	262	2	6	1	0	9	7	214	2	0	223	6	25	5	0	36	530
05:30 PM	6	190	2	0	198	2	9	3	3	17	15	230	2	0	247	10	25	4	0	39	501
05:45 PM	3	187	2	0	192	1	14	1	0	16	18	224	2	0	244	11	23	6	0	40	492
Total	14	869	6	0	889	6	37	8	3	54	45	894	9	0	948	36	98	20	0	154	2045
Grand Total	102	4474	40	5	4621	38	353	23	8	422	182	3981	58	6	4227	120	433	180	2	735	10005
Apprch %	2.2	96.8	0.9	0.1		9	83.6	5.5	1.9		4.3	94.2	1.4	0.1		16.3	58.9	24.5	0.3		
Total %	1	44.7	0.4	0	46.2	0.4	3.5	0.2	0.1	4.2	1.8	39.8	0.6	0.1	42.2	1.2	4.3	1.8	0	7.3	
Cars	100	4393	38	0	4531	36	346	23	0	405	181	3903	54	0	4138	119	422	177	0	718	9792
% Cars	98	98.2	95	0	98.1	94.7	98	100	0	96	99.5	98	93.1	0	97.9	99.2	97.5	98.3	0	97.7	97.9
Buses	1	36	2	0	39	2	6	0	0	8	0	34	3	0	37	1	11	1	0	13	97
% Buses	1	0.8	5	0	0.8	5.3	1.7	0	0	1.9	0	0.9	5.2	0	0.9	0.8	2.5	0.6	0	1.8	1
Trucks	1	45	0	0	46	0	1	0	0	1	1	44	1	0	46	0	0	2	0	2	95
% Trucks	1	1	0	0	1	0	0.3	0	0	0.2	0.5	1.1	1.7	0	1.1	0	0	1.1	0	0.3	0.9
Bicycles on Crosswalk	0	0	0	0	0	0	0	0	0	0	0	0	0	0	0	0	0	0	0	0	0
% Bicycles on Crosswalk	0	0	0	0	0	0	0	0	0	0	0	0	0	0	0	0	0	0	0	0	0
Pedestrians	0	0	0	5	5	0	0	0	8	8	0	0	0	6	6	0	0	0	2	2	21
% Pedestrians	0	0	0	100	0.1	0	0	0	100	1.9	0	0	0	100	0.1	0	0	0	100	0.3	0.2



File Name : Warrensville_Center_Road_at_Shelburne_Road_724444_11-14-2019
 Site Code : Site 5 - Thursday
 Start Date : 11/14/2019
 Page No : 2

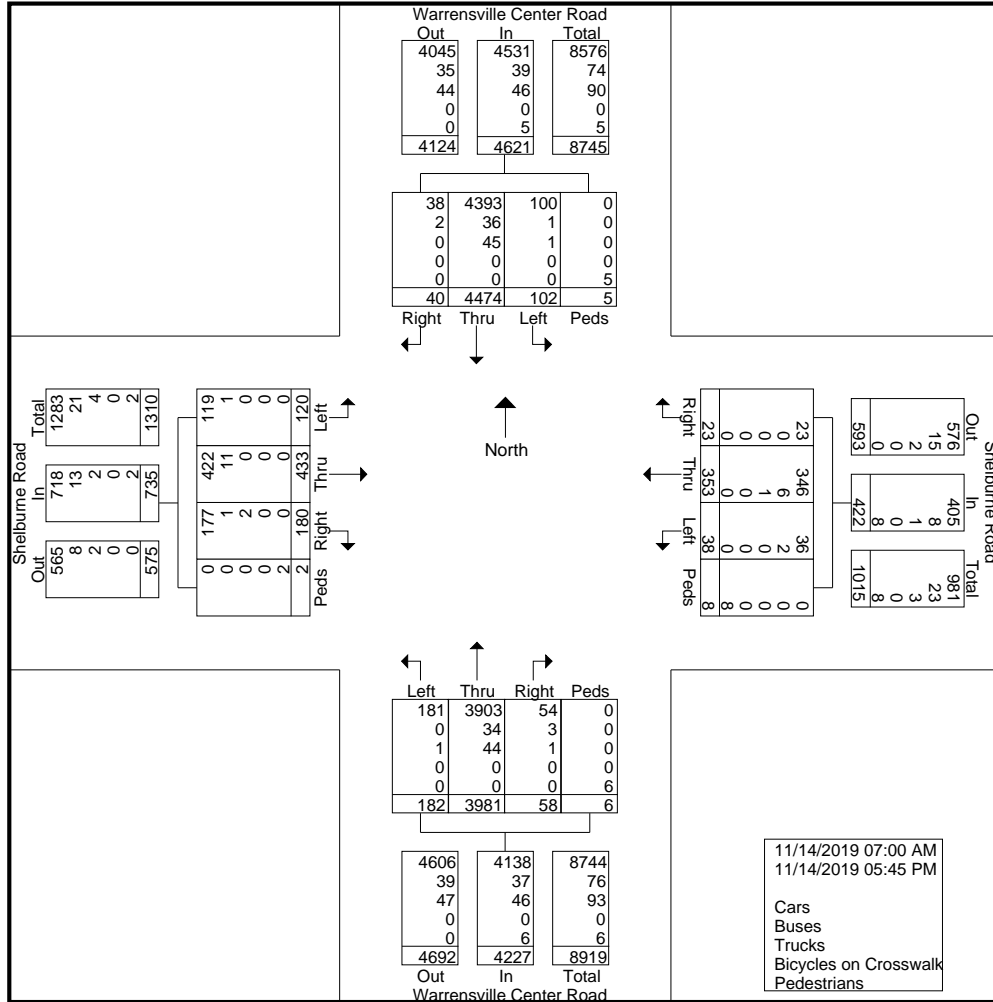



File Name : Warrensville_Center_Road_at_Shelburne_Road_724444_11-14-2019
 Site Code : Site 5 - Thursday
 Start Date : 11/14/2019
 Page No : 3

Start Time	Warrensville Center Road From North					Shelburne Road From East					Warrensville Center Road From South					Shelburne Road From West					Int. Total
	Left	Thru	Right	Peds	App. Total	Left	Thru	Right	Peds	App. Total	Left	Thru	Right	Peds	App. Total	Left	Thru	Right	Peds	App. Total	
Peak Hour Analysis From 07:00 AM to 12:30 PM - Peak 1 of 1																					
Peak Hour for Entire Intersection Begins at 07:30 AM																					
07:30 AM	6	181	2	0	189	1	52	0	1	54	14	124	2	0	140	4	28	16	0	48	431
07:45 AM	3	176	2	0	181	3	36	1	0	40	13	158	2	0	173	6	46	18	0	70	464
08:00 AM	3	178	3	0	184	1	38	3	0	42	4	165	4	0	173	4	14	11	0	29	428
08:15 AM	3	194	3	0	200	0	19	0	0	19	8	127	0	0	135	2	4	9	0	15	369
Total Volume	15	729	10	0	754	5	145	4	1	155	39	574	8	0	621	16	92	54	0	162	1692
% App. Total	2	96.7	1.3	0		3.2	93.5	2.6	0.6		6.3	92.4	1.3	0		9.9	56.8	33.3	0		
PHF	.625	.939	.833	.000	.943	.417	.697	.333	.250	.718	.696	.870	.500	.000	.897	.667	.500	.750	.000	.579	.912

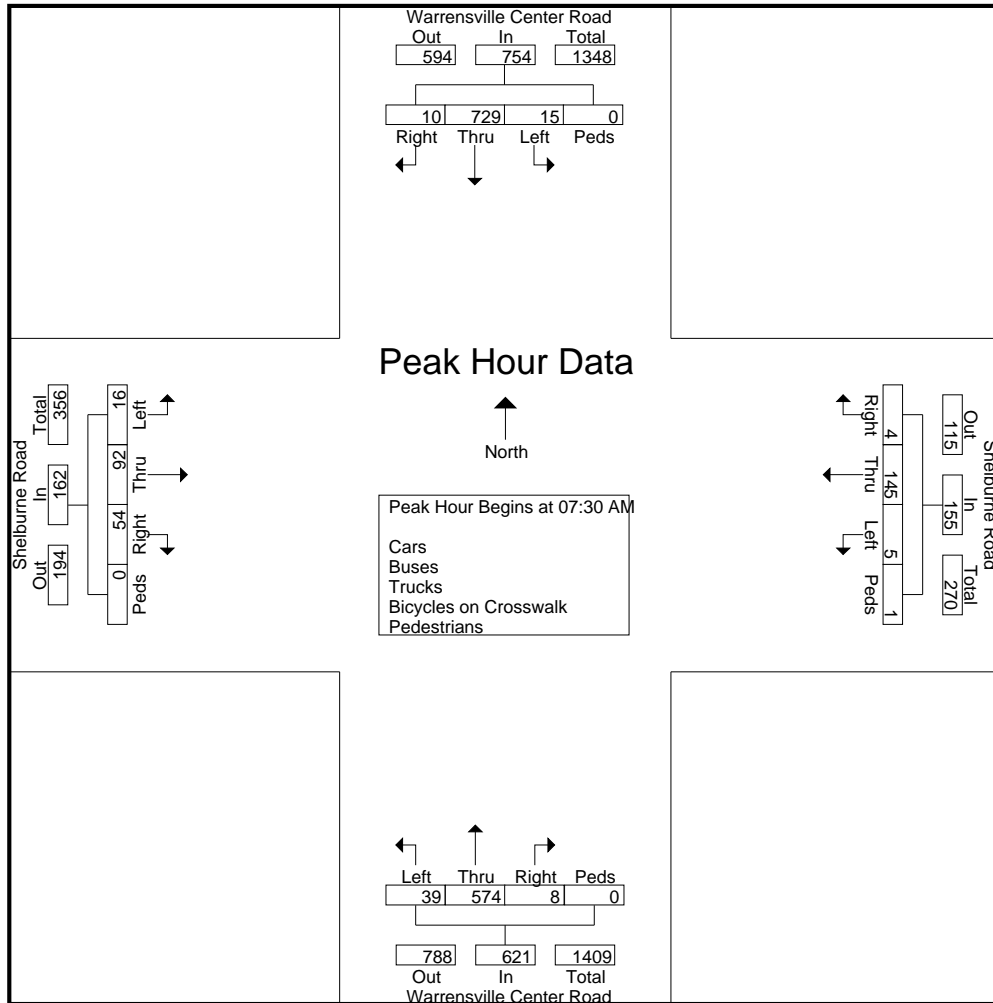



File Name : Warrensville_Center_Road_at_Shelburne_Road_724444_11-14-2019
 Site Code : Site 5 - Thursday
 Start Date : 11/14/2019
 Page No : 4

Start Time	Warrensville Center Road From North					Shelburne Road From East					Warrensville Center Road From South					Shelburne Road From West					Int. Total
	Left	Thru	Right	Peds	App. Total	Left	Thru	Right	Peds	App. Total	Left	Thru	Right	Peds	App. Total	Left	Thru	Right	Peds	App. Total	
Peak Hour Analysis From 12:45 PM to 05:45 PM - Peak 1 of 1																					
Peak Hour for Entire Intersection Begins at 05:00 PM																					
05:00 PM	3	234	0	0	237	1	8	3	0	12	5	226	3	0	234	9	25	5	0	39	522
05:15 PM	2	258	2	0	262	2	6	1	0	9	7	214	2	0	223	6	25	5	0	36	530
05:30 PM	6	190	2	0	198	2	9	3	3	17	15	230	2	0	247	10	25	4	0	39	501
05:45 PM	3	187	2	0	192	1	14	1	0	16	18	224	2	0	244	11	23	6	0	40	492
Total Volume	14	869	6	0	889	6	37	8	3	54	45	894	9	0	948	36	98	20	0	154	2045
% App. Total	1.6	97.8	0.7	0		11.1	68.5	14.8	5.6		4.7	94.3	0.9	0		23.4	63.6	13	0		
PHF	.583	.842	.750	.000	.848	.750	.661	.667	.250	.794	.625	.972	.750	.000	.960	.818	.980	.833	.000	.963	.965

